

# SB600 Series



## Applications

Mechanical and electrical interface between on-board civil avionics equipments and racks

## Standards

Arinc 600

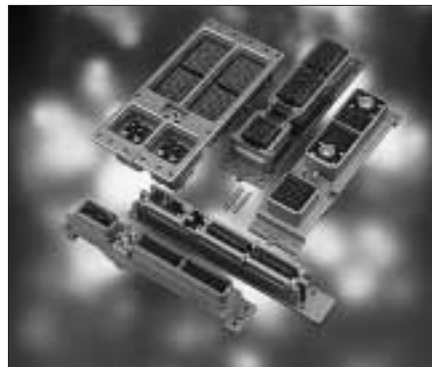

## Description

- Rack and panel connector
- High density up to 800 signal contacts
- Low insertion force contact design (tapered pin, lif socket)
- Sealed and unsealed versions
- Multiple polarizing positions
- Field replaceable thermoset inserts, featuring .006 in true position of contact cavities
- Choice of front and rear removable contacts
- Contacts : signal, power, coaxial, triaxial, filter, optical fiber and waveguide connection contacts
- Wide range of high performance rack applications

## Characteristics

### Mechanical

	material	finish
shells	aluminum alloy to QQ-A-591	alodine 1200 passivation to MIL-C 5541 class 1
insulator	epoxy resin thermoset	
seals and grommets	fluorinated silicon to MIL-R-25988	
contacts	copper alloy to QQ-B-626	gold plated to MIL-G-45204 over nickel to QQ-N-290

- endurance : 500 matings
- insertion and extraction forces max :  
shell size 1 : 120N (27 lbs)  
shell size 2 : 267N (60 lbs)  
shell size 3 : 467N (105 lbs)
- vibration : 8 hours in each axis. Random vibration at 16.4 g Rms from 50 to 2000 Hz. MIL-STD-1344 A method 2005-1
- dynamic shock : 3 impacts of 50 g in all axis, duration 11µs (half wave) to MIL-STD-202 method 213

### Electrical

- dielectric withstanding voltage

	mated	unmated
sea level	1 500 Vrms	1 500 Vrms
15 000 m	500 Vrms	500 Vrms

- voltage rating : 500 Vac Max 125 Vac at 21 000 m
- insulation resistance :  $\geq 5000 \text{ M}\Omega$
- current ratings, continuous :

contact	wire gauge	current (A)	voltage drop max (mV)*
22	22	5	40
	24	3	30
	26	2	25
20	20	7,5	55
	22	5	40
	24	3	30
16	16	13	50
12	12	23	45

\* measured over a conductor length of 150 mm

- triaxial contact size 8  
bandwidth : 0-20 MHz - voltage rating : 500 Vac Max 125 Vac at 21 000 m - voltage drop : inner and middle contact  $\leq 55 \text{ mV}$  under 1A - outer contact  $\leq 75 \text{ mV}$  under 12A

### Climatic

- Temperature rating :  $-65^\circ\text{C}$  to  $+125^\circ\text{C}$  for both classes, sealed and unsealed
- Fluid resistance : hydraulic to MIL-H 5606 lubricating to MIL-L 23699 - isopropyl alcohol
- Resistance to salt spray : 48 hours MIL-STD-202 method 101 or MIL-STD-1344 method 1001
- Sealing : environment resistant (sealed version)

## Ordering information

basic series	SB6	0	2	M	G	13	W2	P	00	01	AN
class	<ul style="list-style-type: none"> <li>0 - sealed</li> <li>1 - unsealed</li> <li>2 - semi-environmental (without O-ring)</li> <li>3 - semi-environmental (without O-ring and compound)</li> <li>A - plug semi-environmental (without O-ring and compound) with RFI shielded (only shell size 2 - 3)</li> <li>B - unsealed plug with RFI shielded (only shell size 2 - 3)</li> <li>D - unsealed with grounding fingers</li> </ul>										
shell size	1 - 2 - 3										
shell style	<ul style="list-style-type: none"> <li>M - rack plug</li> <li>F - equipment receptacle</li> </ul>										
series	<ul style="list-style-type: none"> <li>G - rear release signal and power contacts</li> <li>H - front release signal contacts (PC and WW terminations female) and rear release power contacts</li> </ul>										
mounting styles	(see schedule n°1) p 3 9										
insert arrangement code	- in cavities C and F (see schedule n°2 p 3)										
style of signal contacts	<ul style="list-style-type: none"> <li>P - # 22 - male (rack plug)</li> <li>S - # 22 - female (equipment receptacle)</li> </ul>										
insert arrangement code	- in cavities A-B-D-E (see schedule n°3 p 3)										
polarization code	(see schedule n°5 p 4)										
connector packaging code	(see schedule n°4 p 3)										

# SB600 Series



## Contact arrangements in shells

	M : rack plug	F : equipment receptacle
signal contacts	male	female
power contacts	female	male
coaxial and triaxial contacts	female	male

## Contact layouts - assembly alternative Front face of female insulator - equipment receptacle

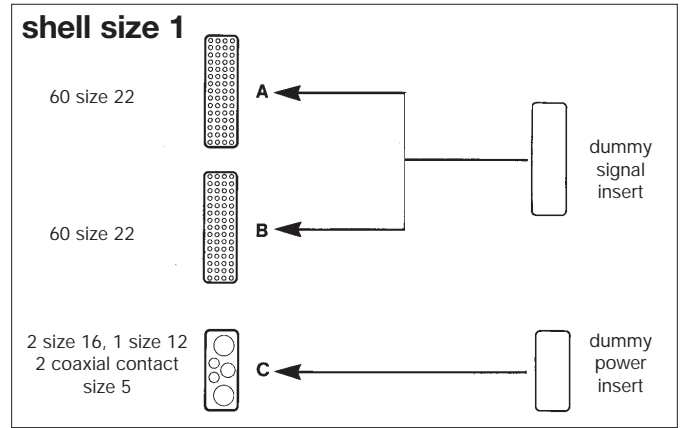

## Contact layouts - assembly alternative

### Front face of female insulator - equipment receptacle

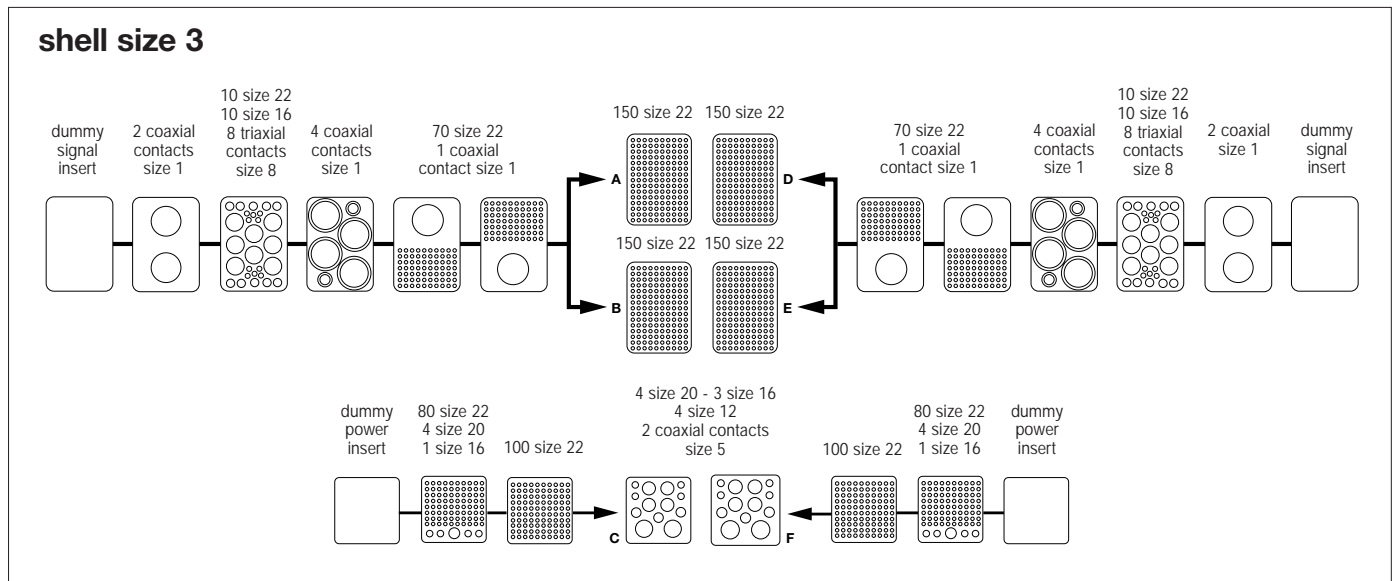
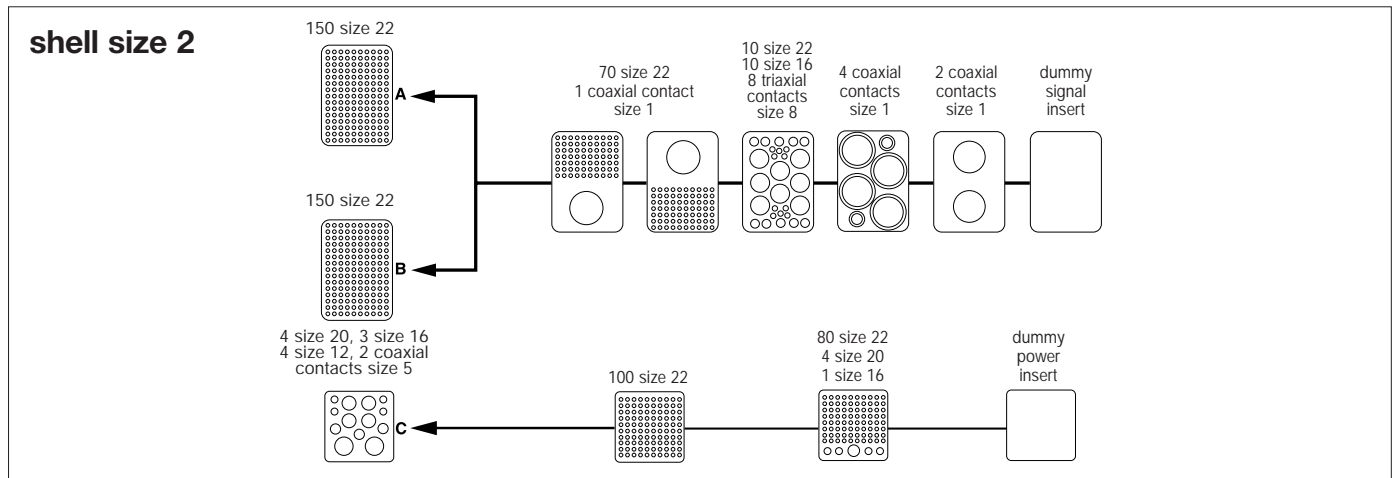

# SB600 Series



## Schedule n°1 mounting styles

- 05** - standard mounting shell size 1
- 13** - standard mounting shell size 2 and 3
- FL** - float mounts 4, 6-32 eyelet
- FN** - float mounts 4, 6-32 self-locking threaded inserts
- FS** - float mounts 4, 4-40 self-locking threaded inserts
- FT** - float mounts 4, 4-40
- LN** - 6-32 self-locking threaded inserts
- SL** - 4-40 self-locking threaded inserts
- TL** - 4-40 self-locking threaded inserts
- TN** - 6-32 self-locking threaded inserts

} see note  
} in all holes

Note :

	receptacle			plug		
shells	1	2	3	1	2	3
numbers of inserts	4	6	10	4	4	8

## Schedule n°2 insert arrangements power cavities C and F

- W2**- standard power insert (rear contact release), shell sizes 1-2-3
- 00** - shell size 1,2 - cavity C dummy insert
- 01** - shell size 3 - cavities C and F dummy insert
- 02** - shell size 3 - cavity C standard insert and cavity F dummy insert
- 03** - shell size 3 - cavity C dummy insert cavity F standard insert
- K1** - shell size 3 - cavities C and F fitted with inserts for 100 size 22 contacts
- K2** - shell size 3 - standard power insert in cavity C plus 100 size 22 signal insert in cavity F
- K3** - shell size 3 - 100 size 22 signal insert in cavity C plus standard power insert in cavity F
- K4** - shell size 2 - cavity C empty
- K5** - shell size 2 - cavity C 100 size 22 signal contact insert
- K9** - shell size 2 - cavity C 100 size 22 signal contact insert rear release (A and B, insert front release)
- A2** - shell size 3 - cavity F empty, cavity C standard insert
- A3** - shell size 3 - cavity F dummy insert, cavity C standard insert

## Schedule n°3 insert arrangements signal cavities A, B, D, E

- 00** - standard signal inserts, shell sizes 1-2-3
  - 01** - shell size 2 - cavities A and B fitted with inserts for 70 size 22 plus 1 size 1 contacts
  - 02** - shell size 2 - standard signal insert in cavity A plus 70 size 22 plus 1 size 1 contact insert in cavity B
  - 03** - shell size 2 - 70 size 22 plus 1 size 1 insert in cavity A plus standard signal insert in cavity B
  - 04** - shell size 2 - cavity A empty and 70 size 22 plus 1 size 1 insert in cavity B
  - 05** - shell size 3 - cavity A and B 2 size 1 insert cavity E standard insert and cavity D empty
  - 07** - shell size 2 - cavity A dummy insert and cavity B 70 size 22 plus 1 size 1 insert
  - 08** - shell size 3 - cavities A, B, D and E 70 size 22 plus 1 size 1 insert
  - 09** - shell size 3 - cavities A, B, D standard insert cavity E 70 size 22 plus 1 size 1 insert
  - A1** - shell size 2
  - A2** - shell size 2
  - A3** - shell size 2
- } same arrangements as 01, 02 and 03 but with size 1 coaxial contact body fitted
- E1** - shell size 2 - cavities A and B empty
  - E2** - shell size 2 - standard signal insert in cavity A, cavity B empty
  - E3** - shell size 2 - cavity A empty, standard signal insert in cavity B
  - E5** - shell size 2 - cavity A empty, cavity B triaxial size 8 insert
  - E6** - shell size 2 - cavity A 2 size 1 insert, cavity B 70 size 22+1 size 1 insert
  - E7** - shell size 3 - cavities A, B, D 2 size 1 insert cavity E standard insert
  - F2** - shell size 2 - cavity A standard insert cavity B waveguide
  - F3** - shell size 2 - cavity A waveguide cavity B standard insert
  - H1** - shell size 2 - cavity A and B triaxial size 8 inserts
  - H2** - shell size 2 - cavity A standard insert cavity B triaxial size 8 insert
  - H3** - shell size 2 - cavity A triaxial size 8 insert cavity B standard insert

- HA** - shell size 3 - cavities A, B, D standard insert cavity E triaxial size 8 insert
- HB** - shell size 3 - cavities A, B, E standard insert cavity D triaxial size 8 insert
- HC** - shell size 3 - cavities A, B standard insert cavities D, E triaxial size 8 insert
- HD** - shell size 3 - cavities A, D, E standard insert cavity B triaxial size 8 insert
- HE** - shell size 3 - cavities A, D standard insert cavities B, E triaxial size 8 insert
- HF** - shell size 3 - cavities A, E standard insert cavities B, D triaxial size 8 insert
- HG** - shell size 3 - cavity A standard insert cavities B, D, E triaxial size 8 insert
- HH** - shell size 3 - cavities B, D, E standard insert cavity A triaxial size 8 insert
- HJ** - shell size 3 - cavities B, D standard insert cavities A, E triaxial size 8 insert
- HK** - shell size 3 - cavities B, E standard insert cavities A, D triaxial size 8 insert
- HL** - shell size 3 - cavity B standard insert cavities A, D, E triaxial size 8 insert
- HM** - shell size 3 - cavities D, E standard insert cavities A, B triaxial size 8 insert
- HN** - shell size 3 - cavity D standard insert cavities A, B, E triaxial size 8 insert
- HP** - shell size 3 - cavity E standard insert cavities A, B, D triaxial size 8 insert
- HQ** - shell size 3 - cavities A, B, D, E triaxial size 8 insert
- L1** - shell size 1-2 - cavity A and B dummy insert
- L2** - shell size 1-2 - cavity A standard insert, cavity B dummy insert
- L3** - shell size 1-2 - cavity A dummy insert, cavity B standard insert

## Schedule n°4 packaging code

(not applicable to connectors where no contacts are specified)

### 1<sup>st</sup> letter signal and power contacts

- A** - connector plus full complement of signal and power contacts, crimp termination
- B** - connector supplied only with signal crimp contact unmounted
- C** - connector supplied with W.W signal contact (L = 12,7 mm) mounted in insulator and without power contacts
- D** - connector plus full complement of WW signal contacts (L = 9,52 mm) and crimp power contacts. Wire wrap and power contacts are delivered unmounted
- E** - connector plus full complement of mounted P C signal contacts (L = 6,35 mm) and crimp power contacts. Straight spill contacts are supplied mounted. Power contacts are supplied unmounted
- I** - connector supplied with straight spill contacts (L = 3,81 mm) and crimp power contacts straight spill contacts are supplied mounted and power contacts are supplied unmounted
- L** - connector without either signal or power contacts

### 2<sup>nd</sup> letter size 1 and size 5 coaxial contacts

- N** - connector without either size 1 or size 5 coaxial contacts
- A** - connector plus size 5 coaxial contacts for RG 58C/U cable plus size 1 coaxial contacts for RG 165/U and RG 225/U cables. (body and termination kit). Coaxial size 5 supplied unmounted. Size 1 supplied mounted or unmounted, as per schedule n°3
- C** - shell size 2-3 - connector supplied with straight size 1 coaxial contact for UT 141-RG 402 B/U cable, contact supplied unmounted
- B** - shell size 2-3 - connector supplied with straight size 1 coaxial contacts for RG 141A/U RG 142 B/U-KX 23 cable, contact supplied unmounted
- D** - connector plus size 5 coaxial contacts for 5021 K 1011 cable
- S** - shell size 2-3 - connector plus size 1 coaxial contacts for suffix E9

Note : Do not use the suffix L and N together

# SB600 Series



## Schedule n°5 polarization

### Rack plug

00 polarizing key delivered unmounted

### Equipment receptacle

00 polarizing eye delivered unmounted

position	L.H. key	centre key	R.H. key	position	L.H. key	centre key	R.H. key
01	1	1	1	01	4	4	4
02	2	1	1	02	4	4	3
03	3	1	1	03	4	4	2
04	4	1	1	04	4	4	1
05	5	1	1	05	4	4	6
06	6	1	1	06	4	4	5
07	1	1	6	07	5	4	4
08	2	1	6	08	5	4	3
09	3	1	6	09	5	4	2
10	4	1	6	10	5	4	1
11	5	1	6	11	5	4	6
12	6	1	6	12	5	4	5
13	1	1	5	13	6	4	4
14	2	1	5	14	6	4	3
15	3	1	5	15	6	4	2
16	4	1	5	16	6	4	1
17	5	1	5	17	6	4	6
18	6	1	5	18	6	4	5
19	1	1	4	19	1	4	4
20	2	1	4	20	1	4	3
21	3	1	4	21	1	4	2
22	4	1	4	22	1	4	1
23	5	1	4	23	1	4	6
24	6	1	4	24	1	4	5
25	1	1	3	25	2	4	4
26	2	1	3	26	2	4	3
27	3	1	3	27	2	4	2
28	4	1	3	28	2	4	1
29	5	1	3	29	2	4	6
30	6	1	3	30	2	4	5
31	1	1	2	31	3	4	4
32	2	1	2	32	3	4	3
33	3	1	2	33	3	4	2
34	4	1	2	34	3	4	1
35	5	1	2	35	3	4	6
36	6	1	2	36	3	4	5
37	1	2	1	37	4	3	4
38	2	2	1	38	4	3	3
39	3	2	1	39	4	3	2
40	4	2	1	40	4	3	1
41	5	2	1	41	4	3	6
42	6	2	1	42	4	3	5
43	1	2	6	43	5	3	4
44	2	2	6	44	5	3	3
45	3	2	6	45	5	3	2
46	4	2	6	46	5	3	1
47	5	2	6	47	5	3	6
48	6	2	6	48	5	3	5
49	1	2	5	49	6	3	4
50	2	2	5	50	6	3	3
51	3	2	5	51	6	3	2
52	4	2	5	52	6	3	1
53	5	2	5	53	6	3	6
54	6	2	5	54	6	3	5
55	1	2	4	55	1	3	4
56	2	2	4	56	1	3	3
57	3	2	4	57	1	3	2
58	4	2	4	58	1	3	1
59	5	2	4	59	1	3	6
60	6	2	4	60	1	3	5
61	1	2	3	61	2	3	4
62	2	2	3	62	2	3	3
63	3	2	3	63	2	3	2
64	4	2	3	64	2	3	1
65	5	2	3	65	2	3	6
66	6	2	3	66	2	3	5
67	1	2	2	67	3	3	4
68	2	2	2	68	3	3	3
69	3	2	2	69	3	3	2
70	4	2	2	70	3	3	1
71	5	2	2	71	3	3	6
72	6	2	2	72	3	3	5
73	1	3	1	73	4	2	4
74	2	3	1	74	4	2	3
75	3	3	1	75	4	2	2
76	4	3	1	76	4	2	1
77	5	3	1	77	4	2	6
78	6	3	1	78	4	2	5
79	1	3	6	79	5	2	4
80	2	3	6	80	5	2	3
81	3	3	6	81	5	2	2
82	4	3	6	82	5	2	1
83	5	3	6	83	5	2	6
84	6	3	6	84	5	2	5
85	1	3	5	85	6	2	4
86	2	3	5	86	6	2	3
87	3	3	5	87	6	2	2
88	4	3	5	88	6	2	1
89	5	3	5	89	6	2	6
90	6	3	5	90	6	2	5
91	1	3	4	91	1	2	4
92	2	3	4	92	1	2	3
93	3	3	4	93	1	2	2
94	4	3	4	94	1	2	1
95	5	3	4	95	1	2	6
96	6	3	4	96	1	2	5
97	1	3	4	97	2	2	4
98	2	3	3	98	2	2	3
99	3	3	3	99	2	2	2

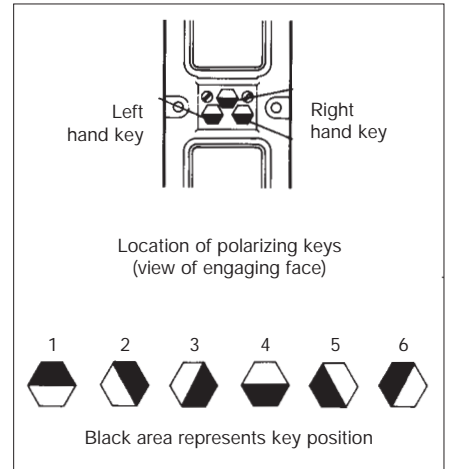

### Polarizing post - rack plug

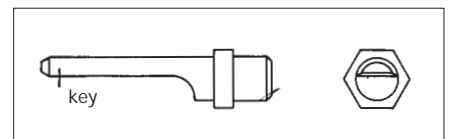

### Polarizing post - equipment receptacle

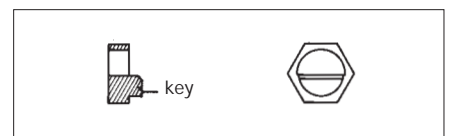

# SB600 Series



## Dimensions of shell size 1

### Rack plug

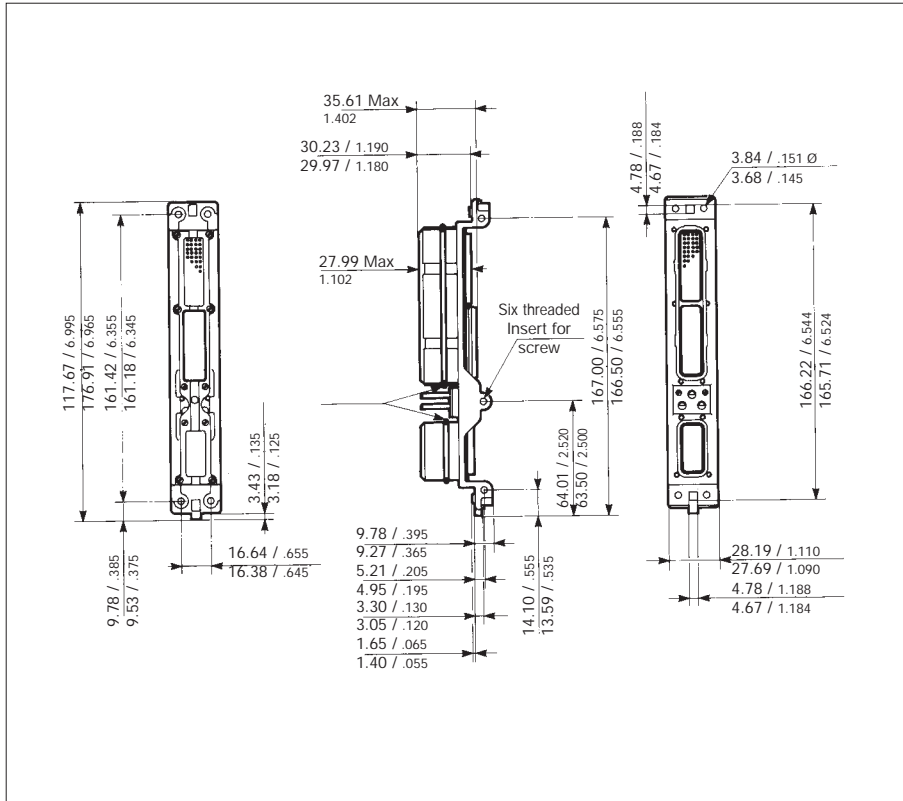

### Panel cut-out

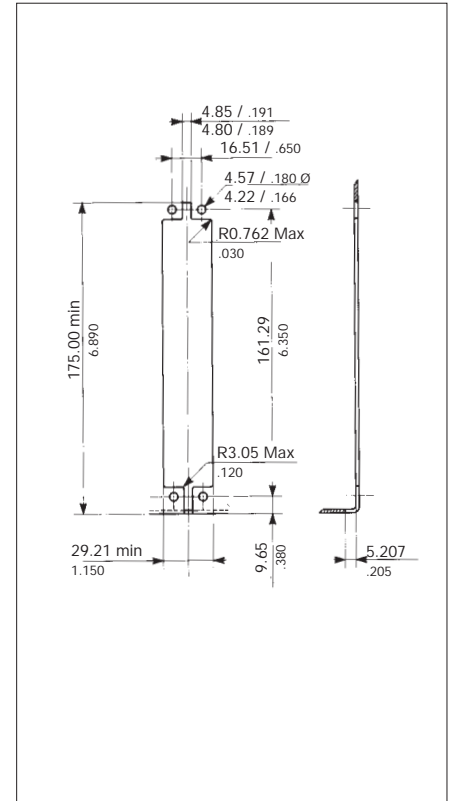

### Equipment receptacle

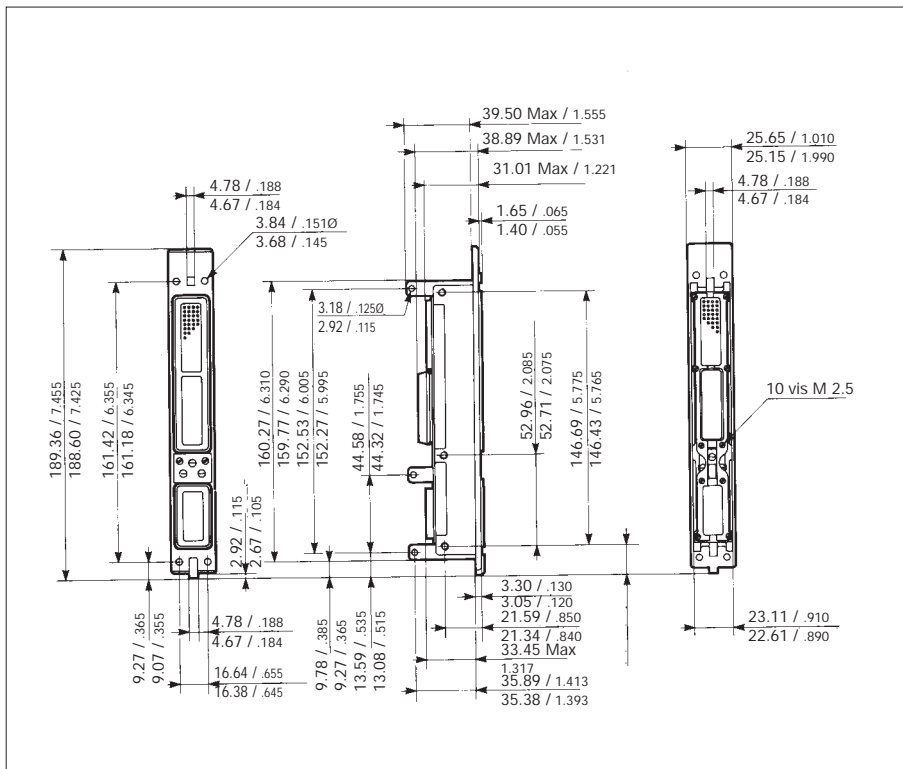

### Panel cut-out

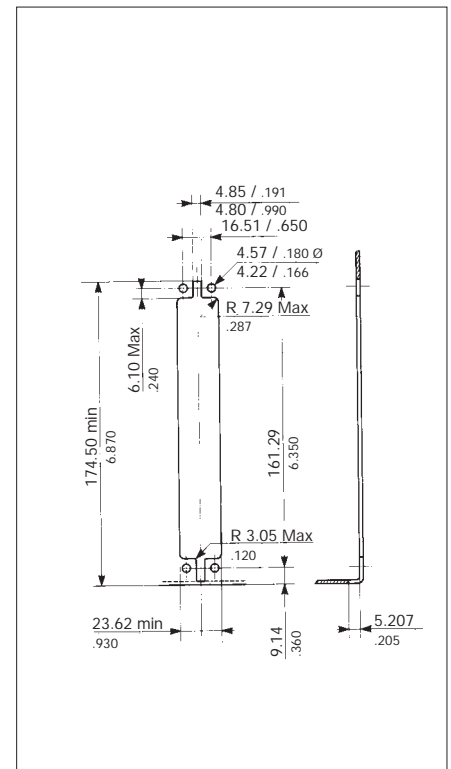

# SB600 Series



## Dimensions of shell size 2

### Rack plug

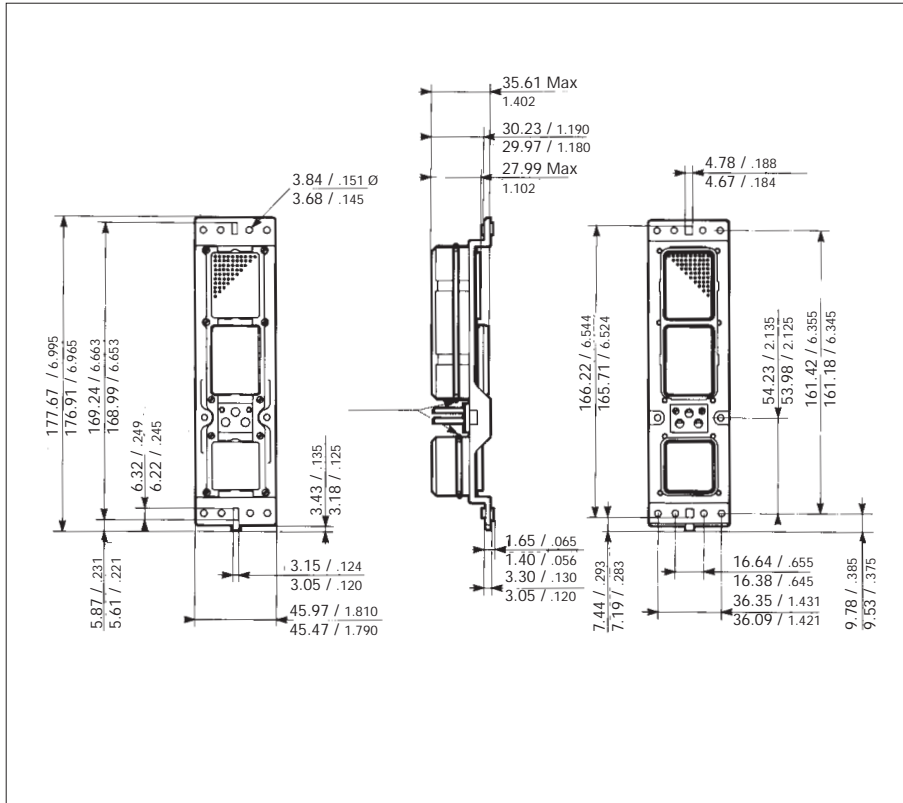

### Panel cut-out

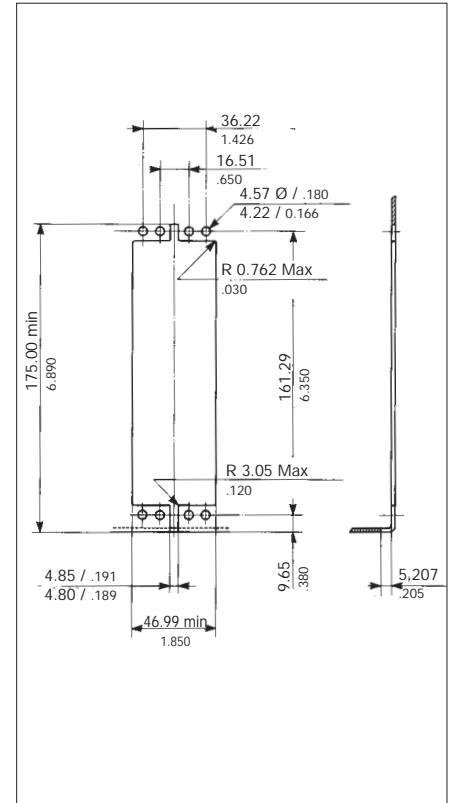

### Equipment receptacle

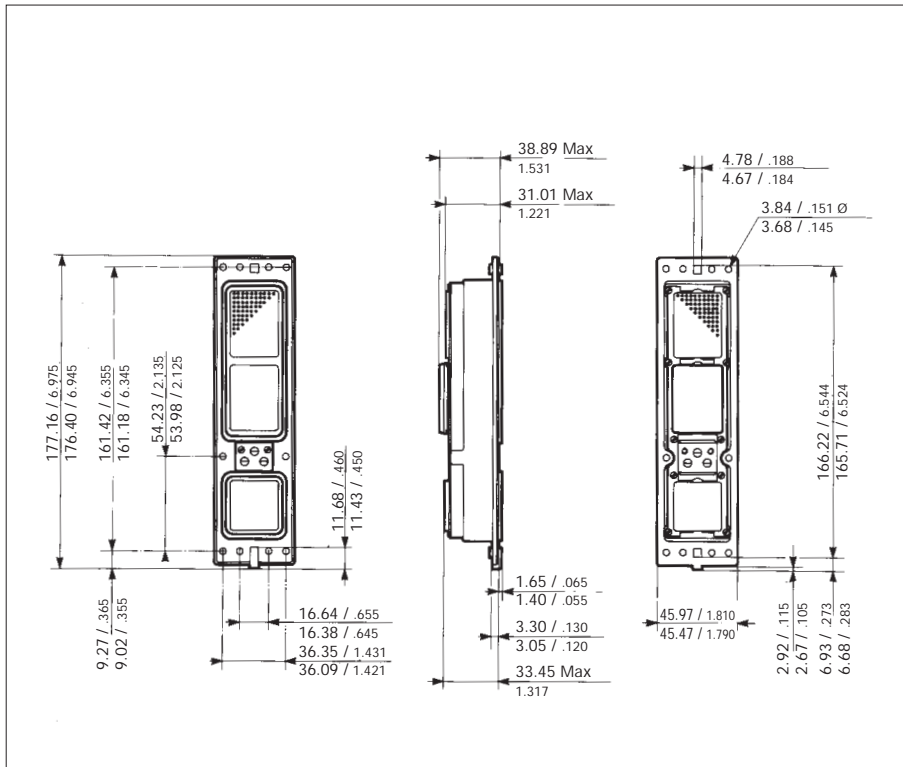

### Panel cut-out

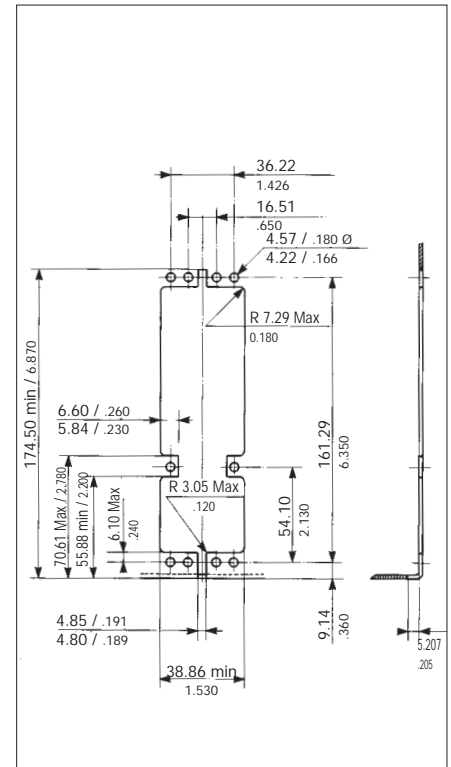

# SB600 Series



## Dimensions of shell size 3

### Rack plug

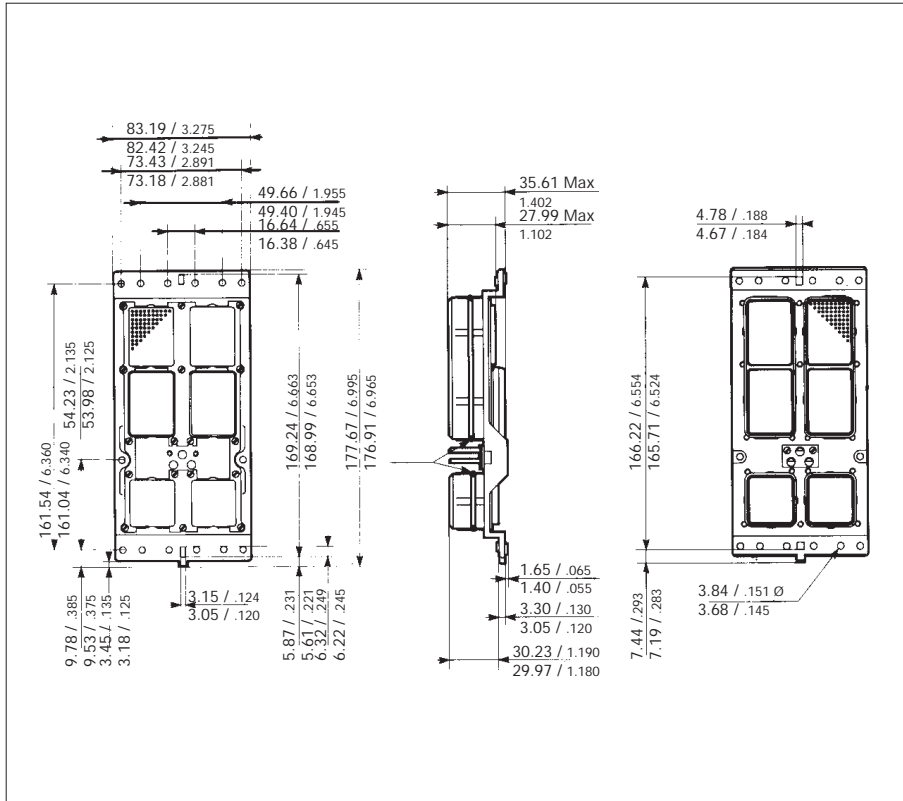

### Panel cut-out

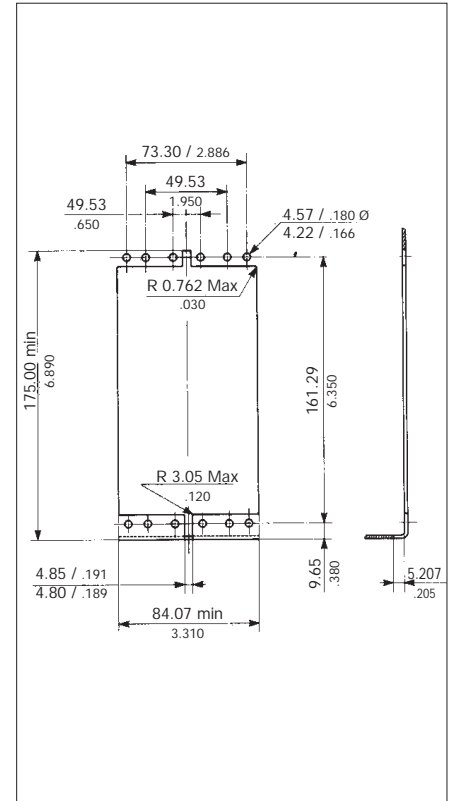

### Equipment receptacle

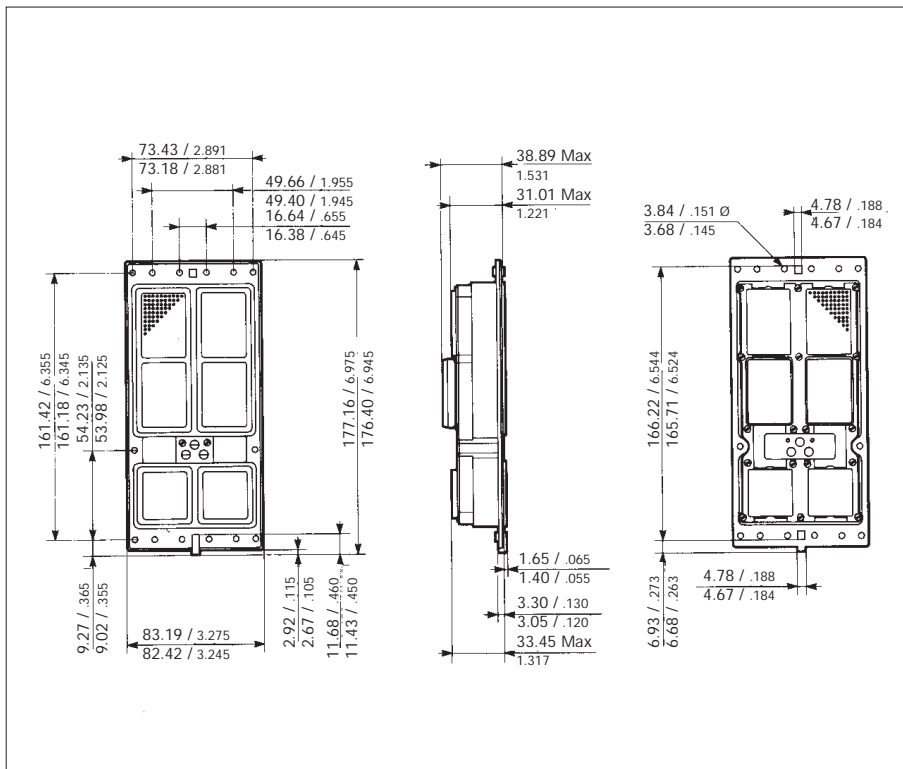

### Panel cut-out

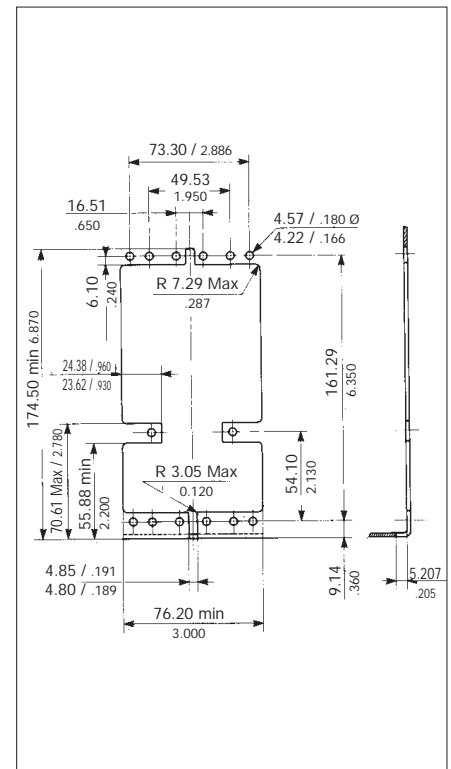

# SB600 Series



## SB 600 PC card drilling dimensions

### Equipment receptacle, shell 1 (viewed from rear face)

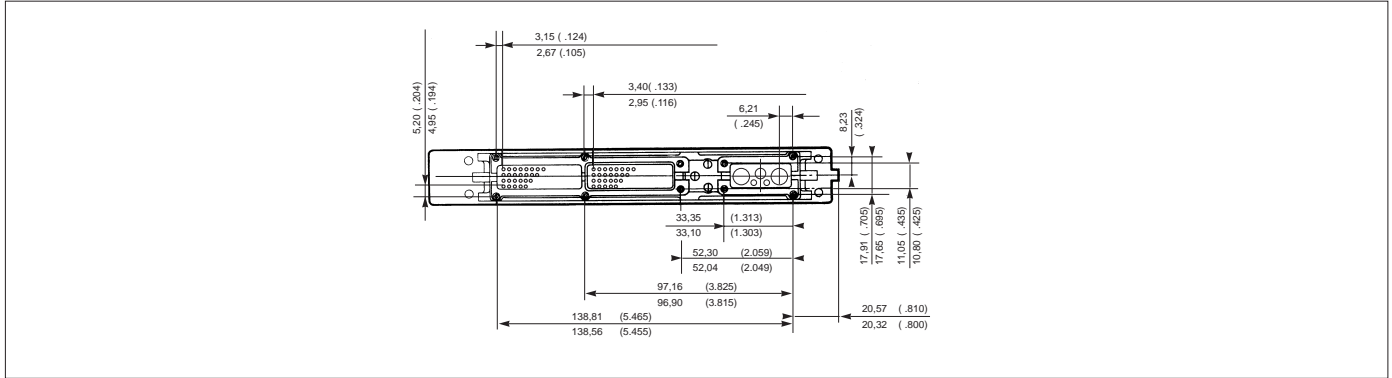

### Equipment receptacle, shell 2 (viewed from rear face)

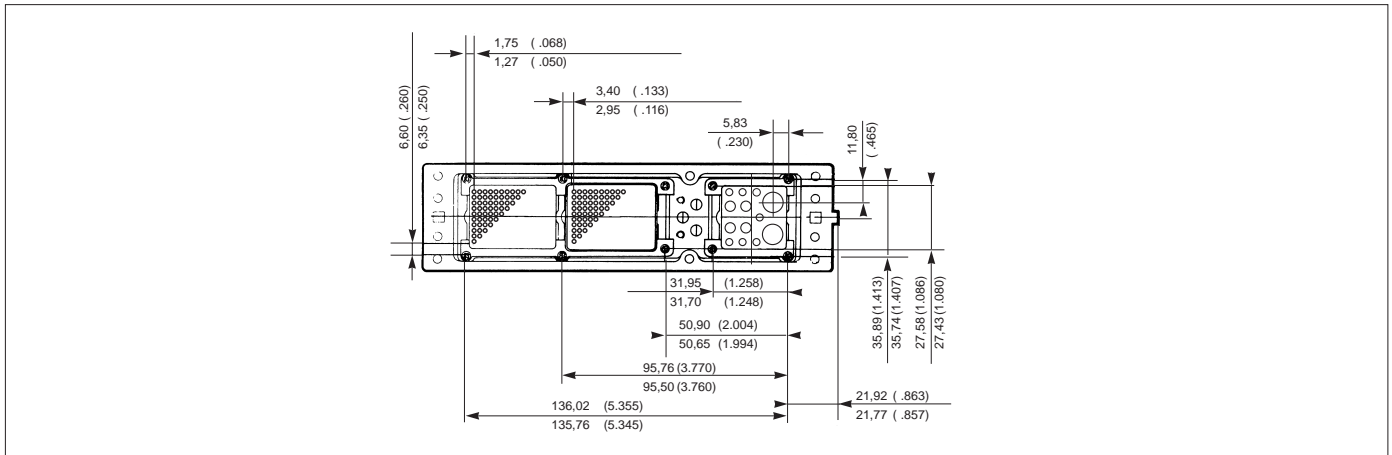

### Equipment receptacle, shell 3 (viewed from rear face)

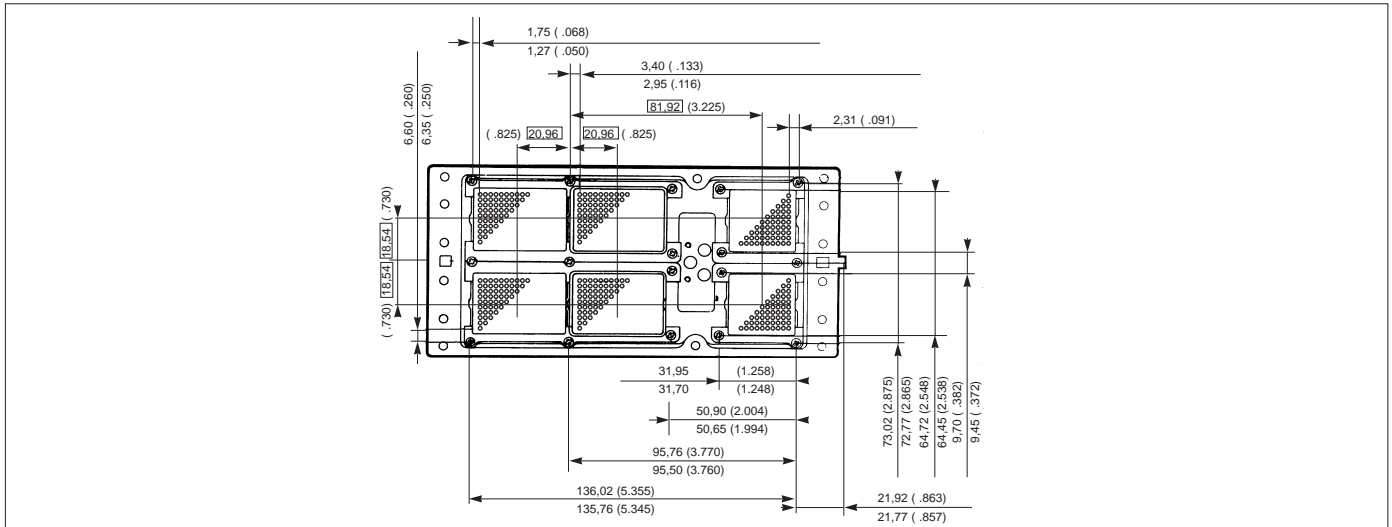

Note : 2.54 mm (.100) pitch between rows.



# SB600 Series



## Accessories

### Standard covers

Supplied with connectors ; but may also be supplied separately.

### Receptacle covers

Red colour.

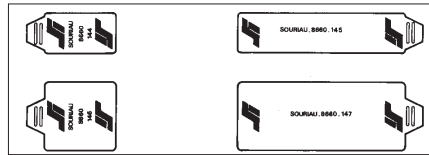

shells	designation	part numbers
1	for power block	8660-144
	for signal block	8660-145
2 and 3	for power block	8660-146
	for signal block	8660-147

### Plug covers

Yellow colour.

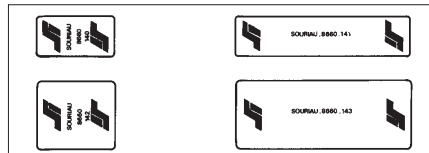

shells	designation	part numbers
1	for power block	8660-140
	for signal block	8660-141
2 and 3	for power block	8660-142
	for signal block	8660-143

### Receptacle conductive covers

Colour : black

These covers are designed to protect equipments against risks of electrostatic discharge.

There are in self-extinguishing polyphenylene with graphic filler.

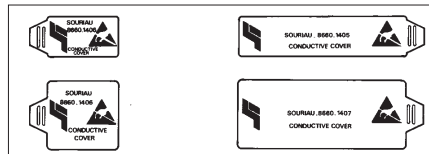

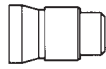
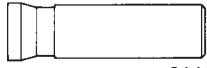
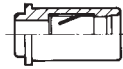
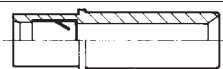

shells	designation	part numbers
1	for power block	8660-1404
	for signal block	8660-1405
2 and 3	for power block	8660-1406
	for signal block	8660-1407

## Cavity reducers



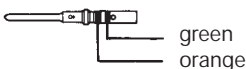
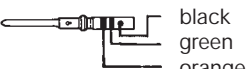

	for equipment receptacle	for rack plug
for adapting size 5 cavities to incorporate size 12 contacts	 8660-343	 8660-344
for adapting size 8 cavities to incorporate size 12 contacts	 8660-537	 8660-536
for adapting size 8 cavities to incorporate size 16 contacts (38999)	8660-3134	8660-3133

## Contact part numbers

### For rack plug male signal contacts - rear release

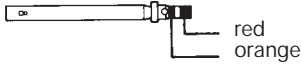
	contact sizes	part numbers	
crimp	22 standard	8660-202	 green orange
	22 alumel	8660-209	 black green orange
	22 chromel	8660-208	 yellow green orange
	22 constantan	8660-209	 red green orange

### female power contacts - rear release

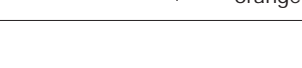
	contact sizes	part numbers	
crimp	20 standard	8660-248	 red orange
	16 standard	8660-249	 blue orange
	16 small barrel	8660-2575	 orange
	12 standard	8660-250	 yellow orange
	12 small barrel	8660-257	 orange

# SB600 Series



## For equipment receptacle female signal contacts - rear release

	contact sizes	part numbers	
crimp	22 standard	8660-206	green orange
	22 alumel	8660-211	black green orange
	22 chromel	8660-210	yellow green orange
	22 constantan	8660-2034	red green orange

## male power contacts - rear release

	contact sizes	part numbers	
crimp	20 standard	8660-230	red orange
	16 standard	8660-233	blue orange
	16 small barrel	8660-1048	orange
	12 standard	8660-236	yellow orange
straight spill	12 small barrel	8660-1049	orange
	20	8660-543 L=3.81 / .150 Ø=0.81mm	orange
	16	8660-546 L=3.81 / .150 Ø=1.27mm	orange
	12	8660-549 L=3.81 / .150 Ø=2.05mm	orange

## female signal contacts - front release

	22	gold plated	tin plated	
		8660-550	8660-C23-22V-01A/06	
L = 3.81 (.150)				
straight spill	22	8660-555	8660-C23-22V-02A/06	
		L = 6.35 (.250)		
		8660-560	8660-C23-22V-03A/06	
		L = 9.52 (.375)		
ww	22	8660-565	8660-C23-22V-04A/06	
		L = 12.70 (.500)		
		8660-223	L = 6.35 (.250)	
ww	22	8660-224	L = 9.52 (.375)	
		L = 12.70 (.500)		
		8660-225	L = 12.70 (.500)	

## Male and female power contacts rear release

Used these contacts for insulators

Part numbers : 8660-J31-200-14A/00 8660-J30-200-14A/00  
8660-J31-200-04A/00 8660-J30-200-04A/00

standard contacts			MIL-C contacts	
contact size	contact type	part numbers without colour code	part numbers	profile and colour code
16	male	8599-0704	M39029/58-364	orange blue yellow
	female	8599-0708	M39029/56-352	orange green red

## filler plug (sealed version)

cavities size	filler plug part numbers	colour
22	8660-212	black
20	8522-389 A	red
16	8522-390 A	blue
12	8522-391 A	yellow
05	8660-726	white
08	8660-3035	red

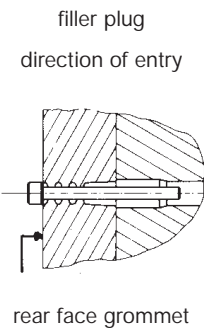

## Dummy contacts (unsealed version)

cavities size	dummy contact part numbers	colour
22 rear release	8660-500	black
22 front release	8660-499	aluminum
20	8660-501	red
16	8660-502	blue
12	8660-503	yellow
5	for plug 8660-505 for receptacle 8660-504	white
8	8660-3131 (plug)	red
8	8660-3132 (receptacle)	red
16	(38999) 8660-3138 (plug)	blue
16	(38999) 8660-3139 (receptacle)	blue

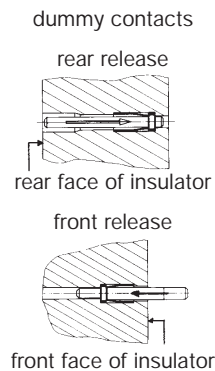

## wire data for crimp contacts

size	cables		Ø over insulation	
	mm <sup>2</sup>	AWG	min (in mm)	max
22	0.15 to 0.38	26-24-22	0.70	1.35
20	0.21 to 0.60	24-22-20	1.02	1.80
16	0.60 to 1.34	20-18-16	1.73	2.60
16 small barrel	0.21 to 0.93	24-22-20-18	1.73	2.60
12	1.91 to 3.18	14-12	2.48	3.40
12 small barrel	0.21 to 0.93	24-22-20-18	2.48	3.40

# SB600 Series



## Coaxial contacts size 5 For equipment receptacle male contact

coaxial		cables
sealed connector	unsealed connector	
8660-2480	8660-2280	RG 58 C/U - RG 142 B/U RG 141 A/U
8660-2481	8660-2281	RG 174 A/U RG 188 A/U
8660-2482	8660-2282	RG 223/U KX 23
8660-2483	8660-2283	RG 178 B/U - KX 21 A RG 196 A/U - KX 22 A RG 316/U
8660-2484	8660-2284	RG 180 B/U RG 195 A/U
8660-2294	8660-2494	5021 K 1011

## For rack plug female contact

coaxial		cables
sealed connector	unsealed connector	
8660-2485	8660-2285	RG 58 C/U - RG 142 B/U RG 141 A/U
8660-2486	8660-2286	RG 174 A/U RG 188 A/U
8660-2487	8660-2287	RG 223/U KX 23
8660-2488	8660-2288	RG 178 B/U - KX 21 A RG 196 A/U - KX 22 A RG 316/U
8660-2489	8660-2289	RG 180 B/U RG 195 A/U
8660-2298E	8660-2498E	5021 K 1011

## For equipment receptacle male contact



## For rack plug female contact

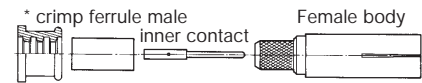

\* Sealing sleeve supplied for Sealed. Connector class 0  
Note : for details of other contacts and cables, please enquire

## Triaxial contacts size 8 For equipment receptacle male contact

class	part numbers	
0 sealed	8599-5210	
1 unsealed	8599-0988	

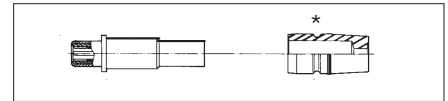

## For rack plug female contact

class	part numbers	
0 sealed	8599-5220	
1 unsealed	8599-0998	

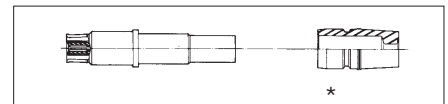

\* Sealing sleeve supplied for Sealed. Connector class 0

## Coaxial contacts size 1 For equipment receptacle male contact

class	coaxial	termination kit	coaxial assembly	cables
0 sealed	8660-2272	8660-2581	8660-2251	RG 141 A/U RG 142 B/U KX 23
		8660-2582	8660-2252	UT 141
		8660-2583	8660-2250	RG 165/U RG 214/U RG 225/U
		8660-2588	8660-2254	RG 393/U
		8660-2236	8660-2313	Fileca 1703/3 Filotex 50 MTKT
1 unsealed	8660-2274	8660-2581	8660-2241	RG 141 A/U RG 142 B/U KX 23
		8660-2582	8660-2242	UT 141
		8660-2583	8660-2240	RG 165/U RG 214/U RG 225/U
		8660-2588	8660-2244	RG 393/U
		8660-2236	8660-2314	Fileca 1703/3 Filotex 50 MTKT

## For rack plug female contact

class	coaxial	termination kit	coaxial assembly	cables
0 sealed	8660-2277	8660-2587	8660-2296	RG 141 A/U RG 142 B/U KX 23
		-	-	-
		8660-2580	8660-2295	RG 165/U RG 214/U RG 225/U
		8660-2585	8660-2299	RG 393/U
		8660-2237	8660-2311	Fileca 1703/3 Filotex 50 MTKT
1 unsealed	8660-2784	8660-2587	8660-2261	RG 141 A/U RG 142 B/U KX 23
		-	-	-
		8660-2580	8660-2260	RG 165/U RG 214/U RG 225/U
		8660-2585	8660-2263	RG 393/U
		8660-2237	8660-2259	Fileca 1703/3 Filotex 50 MTKT
8660-2341	8660-2141	RG 400/BU		

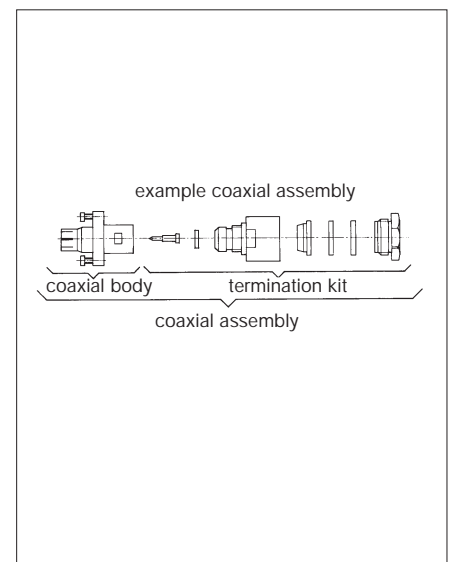

Note : for size 1 90° versions, please enquire

## For rack plug, female contact for insert : 8660-J31-200-06-A/00

part number	cable	profile
8660-D21-100-01A/05	FILOTEX E0406WD FILOTEX 50MFCFB	

# SB600 Series



## Tooling

### Crimping (contacts sizes 22, 20, 16, 12)

contact size	AWG	cables section in mm <sup>2</sup>	part numbers	
			crimping tool	locator
22	22 24 26	0.38 0.21 0.15	8476-01 (M22520/2-01)	8660-216 (M22520/2-23)
20	20 22 24	0.60 0.38 0.21	8476-01 (M22520/2-01)	8476-08 (M22520/2-08)
16	20 18 16	0.60 0.93 1.34	8365 (M22520/1-01)	8365-02 (M22520/1-02)
16 small barrel	24 22 20 18	0.21 0.38 0.60 0.93	8365 (M22520/1-01)	8365-02 (M22520/1-02)
12	14 12	1.91 3.18	8365 (M22520/1-01)	8365-02 (M22520/1-02)
12 small barrel	24 22 20 18	0.21 0.38 0.60 0.93	8365 (M22520/1-01)	8365-02 (M22520/1-02)

### Crimping (size 5 coaxial contacts)

contact part numbers		inner contact		body (ferrule)	
sealed connector	unsealed connector	crimoing tool	locator	crimping tool	hex dies
8660-2480/2485	8660-2280/2285	8476-01 (M22520/2-01)	M22520/2-14	M22520/5-01	M22520/5-45B
8660-2481/2486	8660-2281/2286				M22520/5-37B
8660-2482/2487	8660-2282/2287				M22520/5-45B
8660-2483/2488	8660-2283/2288				M22520/5-37B
8660-2484/2489	8660-2284/2289				M22520/5-43B

Note : size 1 coaxial contacts do not require assembly tooling. Size 8 triaxial contacts : consult wiring instruction : NC 1767 (SHTP).

### Crimping (contact 8660-D21-100-01A/05)

	Crimping tool	locator
inner contact	M22520/1 - 01	M22520/13 SEL - 8
external contact	M22520/5 - 01	M22520/5 - 61

### Contact insertion and extraction

contacts size		insertion and extraction	colour
rear release	22	M81969/1.01	green
	20	8660-188 (M81969/1-02)	red
	16	8522-16 (M81969-14-03)	blue
	12	8522-12 (M81969-14-04)	yellow
	coaxial	insertion : manual	-
	5	extraction : 8660-187 (M81969/28-01)	yellow
	triaxial	insertion : manual	-
front release	8	8660-197	steel
	WW 22	8660-162	red
	straight spill 22	8660-162	red